

Teacher's Preparatory Guide

Powers of Ten with the Morpho Butterfly

Purpose: This activity is designed to help students understand the concept of scale and magnification when examining a Blue Morpho butterfly wing. The activity requires the use of a scanning electron microscope (SEM) but images are provided if there is no access to an SEM.

Time required: one class period

Level: Middle and high school; physical science, general science, biology

Teacher Background: Nanotechnology is the science of the very small where new and unique properties occur in materials. Nanotechnology occurs on the scale of 1-100nm (in one direction) with a nanometer being one billionth of a meter (1×10^{-9}). Scientists and engineers use these unique properties to create new materials and devices. Nature is full of nanoscale materials and processes. Biomimicry is where scientists and engineers use ideas from nature to create new products and develop new solutions to problems. An excellent example is the Blue Morpho butterfly. The beautiful blue colors of this butterfly are not due to pigmentation but to nanoscale surface patterns that interact with light to create iridescence by means of interference. Light waves that interact with the surfaces of the ribbed nanostructures interfere with each other – most are cancelled by this interference resulting in only the blue wavelengths seen by our eyes. When you look at the top of the butterfly wing it has a beautiful blue iridescent color but when you view the underside of the wing it looks brown because of pigmentation. Common examples of physical colors in nature include hummingbird and peacock feathers, some beetles, butterflies, and opal. The structures are often termed natural photonic crystals. Photonics is an exciting area of research that explores ways of using photons (electromagnetic energy) in a variety of devices and materials. To learn more about the Blue Morpho and photonics see the resource section of this lesson.

To see the features on a Blue Morpho butterfly wing, one needs a powerful microscope such as a Scanning Electron Microscope (SEM). An SEM operates by using electrons to create images of the objects being scanned. Nanostructures cannot be seen with light microscopes because they are smaller than the wavelength of visible light – the basis of optical microscopy. The SEM images an object by using an electron gun which supplies electrons that bombard the surface of the object. The electrons travel down the chamber and are focused by a series of condensing lenses. (Figure 1). These electrons excite other electrons out of the specimen which are captured by detectors. Detectors near the object's surface use the electron scatter to form an image, which is projected in gray-scale on a computer screen. The image seen on the screen is a generated model based on the scanning of the electrons. Depending on the device model, the resolution of a SEM can be as small as a few nanometers. Using the SEM allows students to develop an understanding of scale as well as magnification of objects. To learn more about SEMs refer to the resource section of this lesson.

National Nanotechnology Infrastructure Network www.nnin.org

Copyright University of California Santa Barbara and Georgia Institute of Technology 2013

Permission granted for printing and copying for local classroom use without modification

Developed by Marilyn Garza and Nancy Healy

Development and distribution partially funded by the National Science Foundation

NNIN Document: NNIN-1359

Rev: 09/2013

The Blue Morpho's wings consist of a series of overlapping scales which you can see with the SEM. There are two layers of scales – the ground scales which are responsible for the color and the cover scales which are transparent. The ribbed structure of the wings create a spacing of only a few tens of nanometers (90nm) between the ribs which cause an interference pattern when light hits them – similar to what you see with a soap bubble or an oil thin film. The light hitting the top and bottom of the ridges causes interference or the cancelling of certain wavelengths. The light not cancelled out that reaches our eyes is the beautiful blue that we see. While the bottom wing has a similar ridge structure, it also has pigments which result in the dull brown color visible from below.

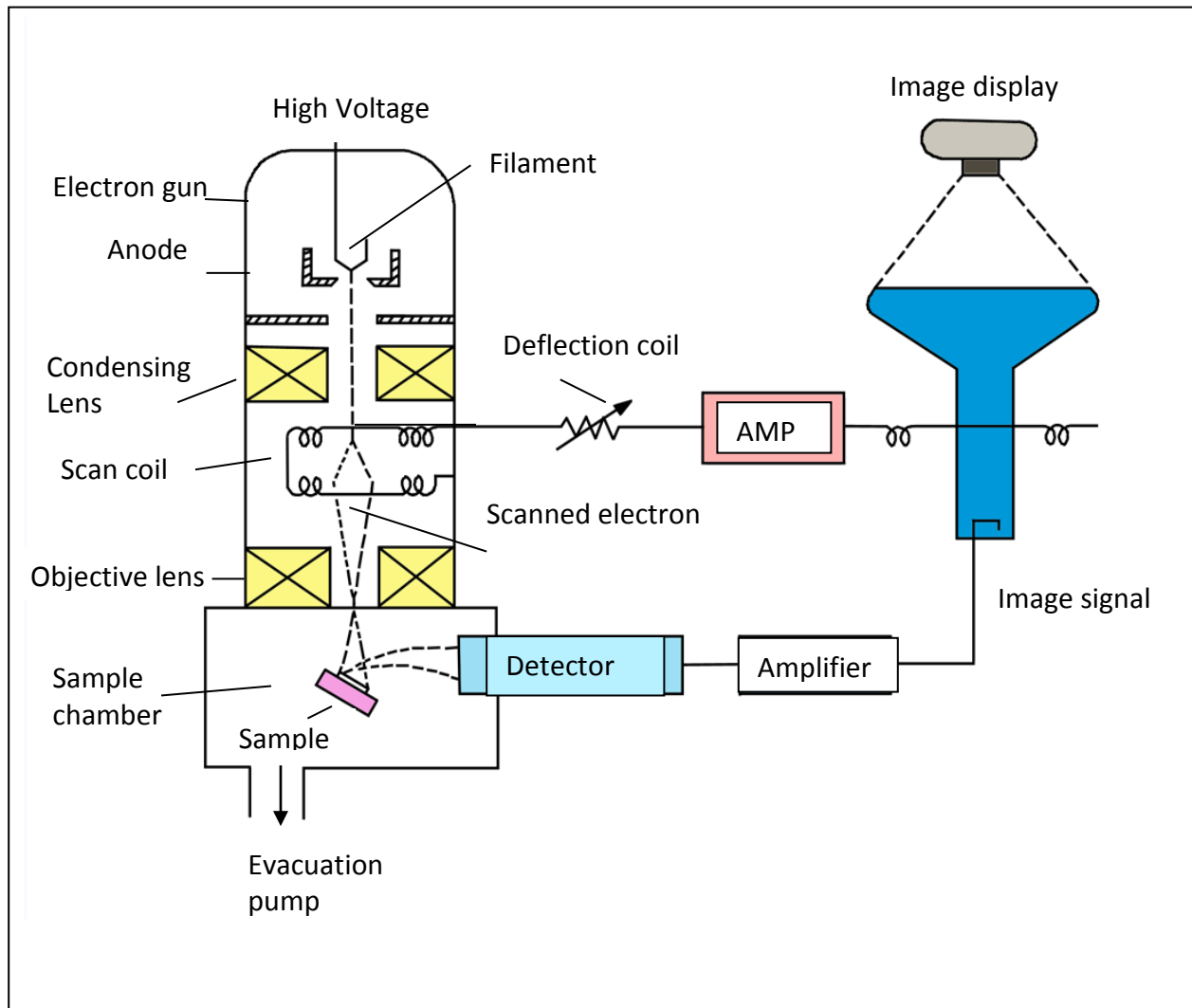

Figure 1. Configuration of a scanning electron microscope. Figure courtesy of Hitachi, HTA

Materials:

- An example of a Blue Morpho butterfly or images of one. If using images, find ones that show both the blue and brown sides of the wings.
 - Mounted Blue Morphos are available on the Internet. A web search will result in a variety of vendors.
- A piece of butterfly wing to image if you have access to an SEM. You can use any butterfly for scanning to see the ribbed structures.
- Images of the Blue Morpho wing (included) if no access to an SEM is available. The images used in the lesson were obtained using Hitachi's TM 3000 Tabletop SEM.

Advance Preparation:

If you are using an SEM, prepare the sample per the instructions for the SEM.

Remote Access: Some universities provide remote access to their SEMs for educational purposes such as these facilities among others found on the web:

- <http://nano4me.org/remotearchive.php>
- http://www.nanotech.ucsb.edu/index.php?option=com_content&view=article&id=506&Itemid=15 ;
- <http://www.sci.sdsu.edu/emfacility/CUCMEoutreach.html>
- http://www.ndsu.edu/em_lab/instrumentation/jeoljism_6490lv/remote_sem_use/
- http://itg.beckman.illinois.edu/technology_development/remote_microscopy/

If you are not using the SEM, print out the images attached to this lesson.

Safety Information: There are no safety issues with this lesson.

Directions for the Activity: See student worksheet for the directions. Students will indicate that the color differences are due to pigmentation in the wings. Some may understand that there are structures on the wings that may cause the colors. Once they have come up with their hypothesis, you can discuss what is causing the iridescence on the upper wing. You may also want to show the YouTube video in the resource section.

Student Worksheet

(with answers)

Powers of Ten with the Morpho Butterfly

Introduction

Nature is full of nanoscale materials and processes. Biomimicry is where scientists and engineers use ideas from nature to create new products and develop new solutions to problems. The *Blue Morpho* butterfly has iridescent blue colored wings when viewed from the top, but the wings look brown when viewed from underneath. You will investigate why it exhibits these colors. You will use images from a scanning electron microscope (SEM) to investigate and hypothesize the cause of this difference in color.

To see the features on a Blue Morpho butterfly wing, one needs a powerful microscope such as a Scanning Electron Microscope (SEM). An SEM operates by using electrons to create images of the objects being scanned. Nanostructures cannot be seen with light microscopes because they are smaller than the wavelength of visible light – the basis of optical microscopy.

Make a Prediction: Why is the Blue Morpho such an iridescent blue?

Materials

- Blue Morpho butterfly (mounted)
- SEM images of Blue Morpho

Procedure:

1. Observe the top side of a *Blue Morpho* butterfly wing sample images at three different magnifications (100X; 1,000X; 10,000X). Sketch your observations at these three different magnifications in the boxes below.
2. Use the same three magnifications to observe the bottom side of a *Blue Morpho* butterfly wing sample. Sketch your observations at three different magnifications in the boxes below.
3. Propose a hypothesis to explain the difference in color that is seen from one side of the wing to the other based upon your observations.

Observations:

Sketches of wings at three different magnifications

Top side wing sample	Bottom side wing sample
----------------------	-------------------------

National Nanotechnology Infrastructure Network www.nnin.org
Copyright University of California Santa Barbara and Georgia Institute of Technology 2013
Permission granted for printing and copying for local classroom use without modification
Developed by Marilyn Garza and Nancy Healy
Development and distribution partially funded by the National Science Foundation

NNIN Document: NNIN-1359
Rev: 09/2013

Magnification: _____	
Magnification: _____	
Magnification: _____	

Top View of the Blue Morpho Butterfly Wing



Photo credit: Johan J.Ingles-Le Nobel
<http://www.flickr.com/photos/jingleslenobel/4370125469/>

Bottom (underside) View of the Blue Morpho Butterfly Wing

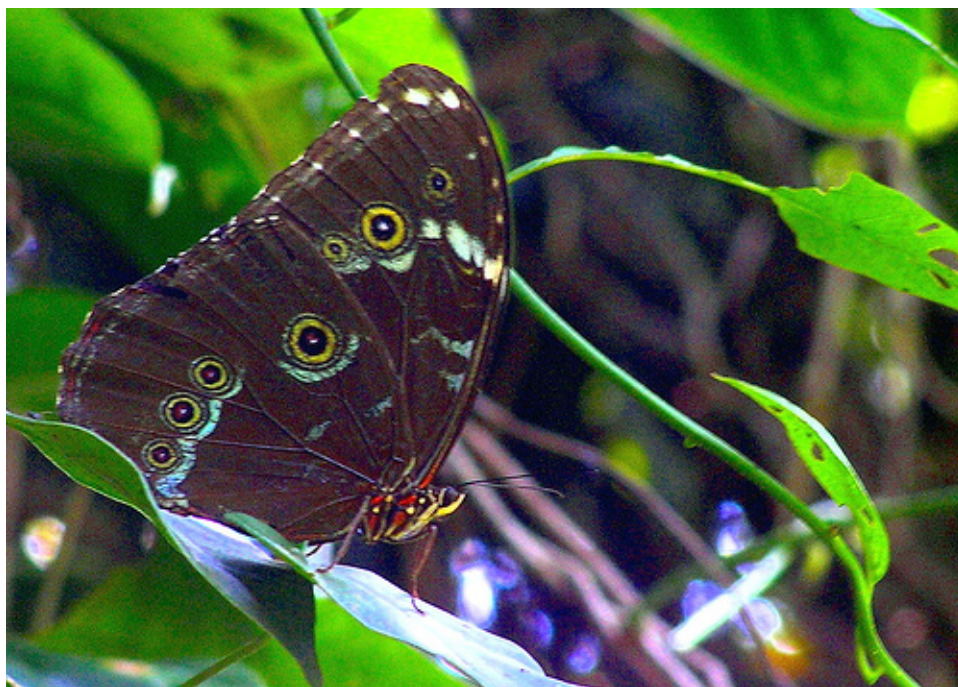

Photo credit: Pierre Pouliquin
http://www.flickr.com/photos/pierre_pouliquin/482340646

National Nanotechnology Infrastructure Network

Copyright University of California Santa Barbara and Georgia Institute of Technology 2013

Permission granted for printing and copying for local classroom use without modification

Developed by Marilyn Garza and Nancy Healy

Development and distribution partially funded by the National Science Foundation

www.nnin.org

NNIN Document: NNIN-1359

Rev: 09/2013



Description:

The object is a part of a wing of a blue Morpho Butterfly. The top part is an iridescent blue while the underside is a brown shade. These are SEM images of the blue side at four magnifications.

Magnification: 10 X

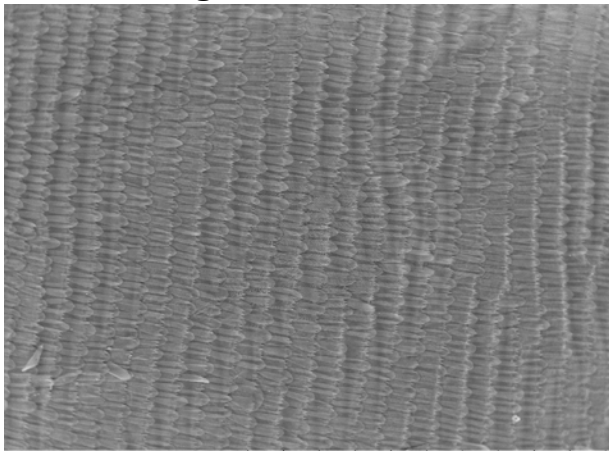

TM3000_0190 2013/05/09 14:35 NL D3.9 x50 2 mm
blue side morpho

Magnification: 100 X

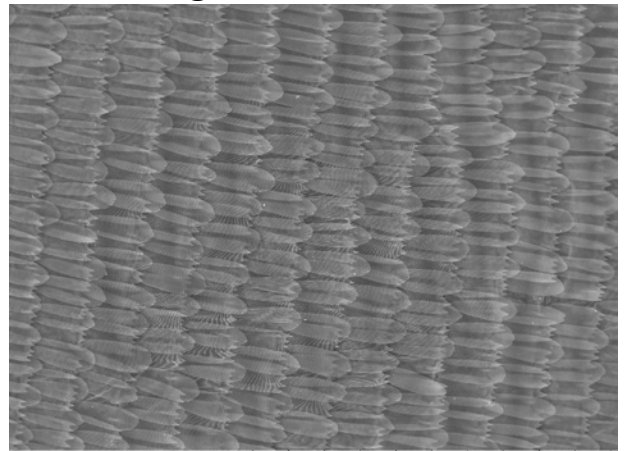

TM3000_0191 2013/05/09 14:37 NL D3.9 x100 1 mm
blue side morpho 2

Magnification: 1,000 X

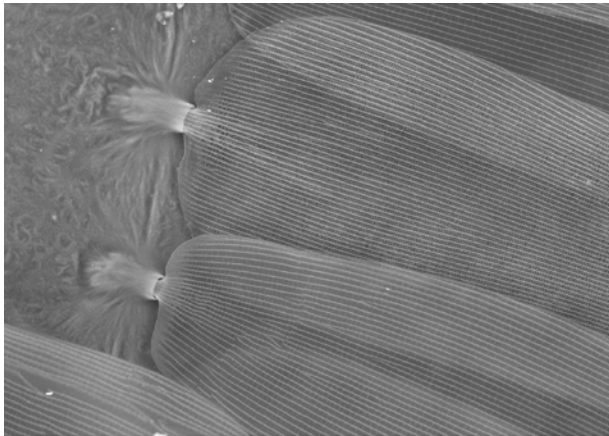

TM3000_0192 2013/05/09 14:45 NL D3.9 x1.0k 100 um
blue side morpho 3

Magnification: 10,000 X

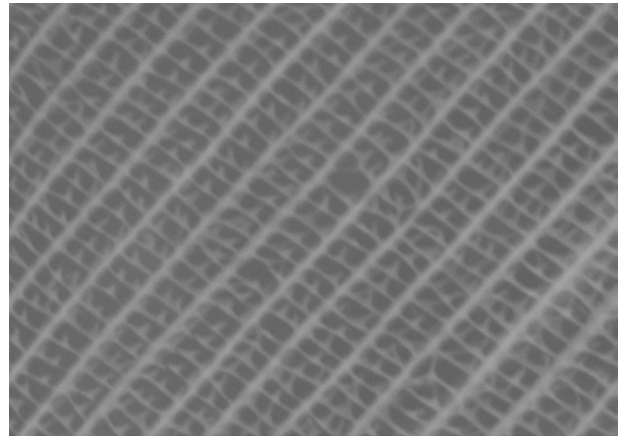

TM3000_0199 2013/05/09 15:27 NL D5.9 x10k 10 um
blue side morpho 9



Description:

The object is a part of a wing of a blue Morpho Butterfly. The top part is an iridescent blue while the underside is a brown shade. These are SEM images of the brown side at four magnifications.

Magnification 100 X

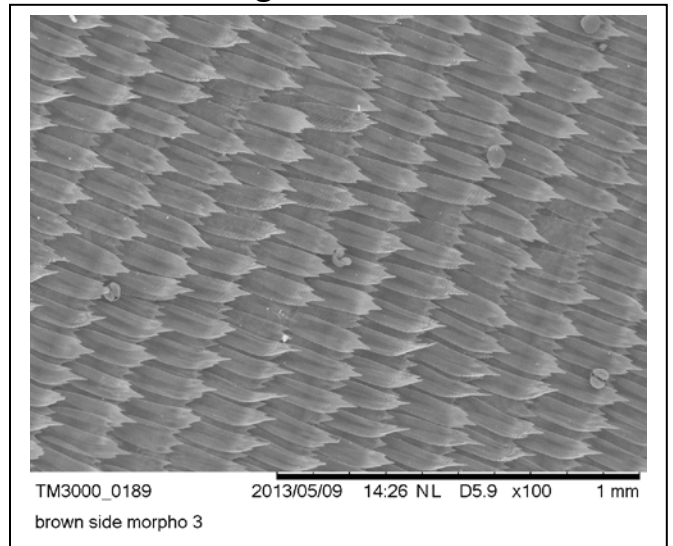
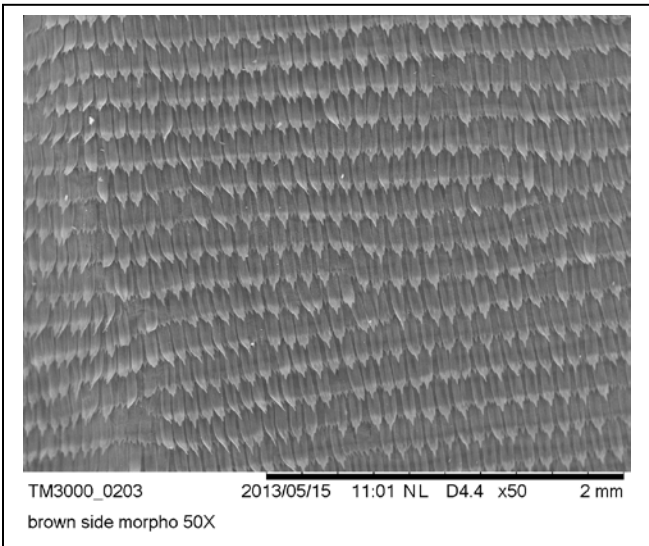

Magnification 1,000 X

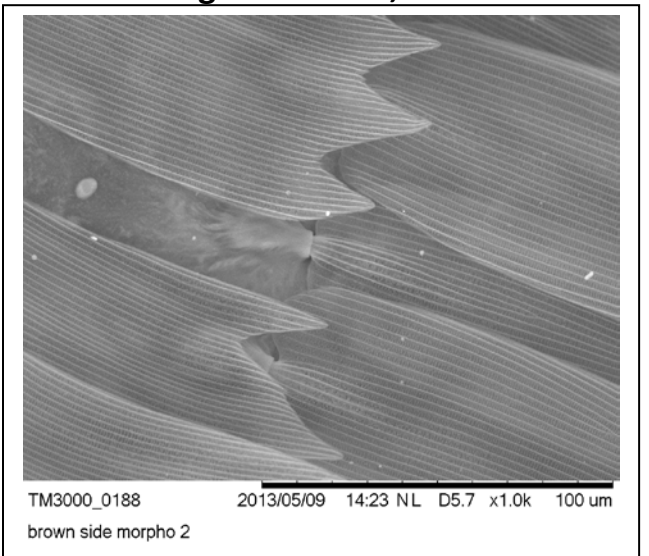

Magnification 10,000 X

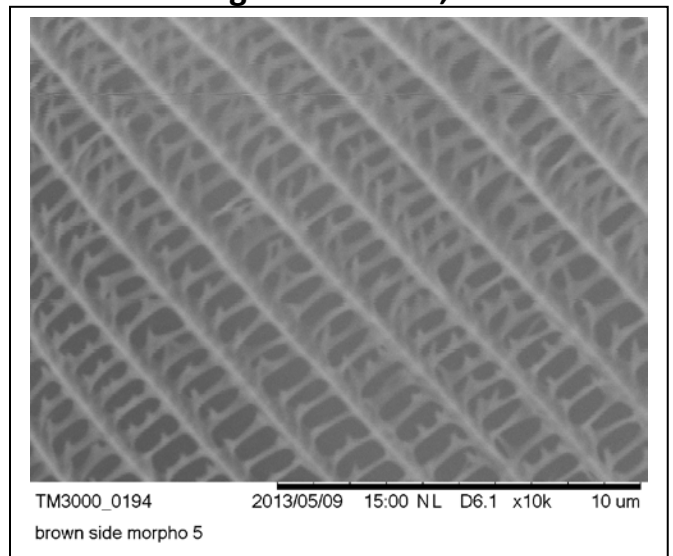

National Nanotechnology Infrastructure Network

Copyright University of California Sana Barbara and Georgia Institute of Technology 2013
 Permission granted for printing and copying for local classroom use without modification
 Developed by Marilyn Garza and Nancy Healy
 Development and distribution partially funded by the National Science Foundation

www.nnin.org

NNIN Document: NNIN-1359

Rev: 09/2013

SEM and the Blue Morpho butterfly

1. Why do scientists and engineers use a scanning electron microscope (SEM) to observe nanoscale materials? Nanoscale materials are below the range of visible light
Students may also provide information on the electromagnetic spectrum and where nano size objects occur.

2. How does an SEM differ from an optical microscope? The SEM uses electrons to scan an object and creates the image by detecting the objects excited electrons. Because it uses electrons which are below the range of visible light, it can only produce images in black and white unlike an optical microscope that allows you to see the color of the object.
3. How do the magnified images of the butterfly differ from the macro-size image? Answers will vary but the students should discuss how with increased magnification they can see more detail structures that make up the wing.

4. What are some of the unique features that you could see with the SEM that were not visible with the unaided eye? Answers will vary but the students should discuss how they can see the individual scales and how they are layered. They should also discuss how they can see the fine features of the ribs and spacing between the ribs.
5. How did the brown side of the butterfly differ from the blue side? They should note that there are no structural differences. The wings are composed on scales and that at high magnification the scales consist of ridges.

6. What do you think causes the brilliant blue color of the Morpho Butterfly? Students will probably think it is due to pigmentation but if they listen to the teacher they should know that the color is due to the interaction of light with the ribs that are part of each scale. They will have to be told that the brown side does have pigmentation which causes the color.

Assessment: See attached question sheet

National Nanotechnology Infrastructure Network www.nnin.org

Copyright University of California Santa Barbara and Georgia Institute of Technology 2013

Permission granted for printing and copying for local classroom use without modification

Developed by Marilyn Garza and Nancy Healy

Development and distribution partially funded by the National Science Foundation

NNIN Document: NNIN-1359

Rev: 09/2013

Resources:

To learn more here are some web sites for the Blue Morpho butterfly, SEM, and general nanotechnology:

- Zoom into a blue morph butterfly – Lawrence Hall of Science
<http://www.youtube.com/watch?v=-TwFEDDF9CQ>
- Biomimicry and Butterflies – Smithsonian <http://www.youtube.com/watch?v=QpEsb-fun44>
- Natural Photonic Crystals -
http://www.viewsfromscience.com/documents/webpages/natural_photonics_p1.html
- *The Gecko's Foot: Bio-inspiration – Engineering New Materials from Nature* by Peter Forbes, W.W. Norton & Company, 2006.
- Nanotechnology application - <http://www.technewsworld.com/story/71681.html>
- Biomimicry 3.8 Institute -
<http://www.asknature.org/strategy/1d00d97a206855365c038d57832ebafa>
- University of Virginia virtual SEM lab - <http://virlab.virginia.edu/VL/SEM.htm>
- Discovery Channel Virtual SEM -
<http://school.discoveryeducation.com/lessonplans/interact/vemwindow.html>
- University of Illinois at Urbana-Champaign Virtual Microscope -
<http://virtual.itg.uiuc.edu/>
- US National Nanotechnology Initiative – <http://www.nano.gov>
- Hitachi Inspire STEM education - <http://www.inspirestemeducation.us/>
- How an SEM works from How Stuff Works - <http://www.howstuffworks.com/scanning-electron-microscope.htm>

National Science Education Standards

Next Generation Science Standards

- MS-PS4-2. Develop and use a model to describe that waves are reflected, absorbed, or transmitted through various materials.
- HS-PS4-4. Evaluate the validity and reliability of claims in published materials of the effects that different frequencies of electromagnetic radiation have when absorbed by matter.

National Nanotechnology Infrastructure Network www.nnin.org

Copyright University of California Santa Barbara and Georgia Institute of Technology 2013

Permission granted for printing and copying for local classroom use without modification

Developed by Marilyn Garza and Nancy Healy

Development and distribution partially funded by the National Science Foundation

NNIN Document: NNIN-1359

Rev: 09/2013